

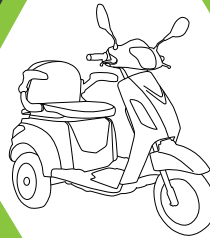

[www.volta.com.tr](http://www.volta.com.tr)

# TRICYCLE USER MANUAL

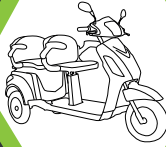
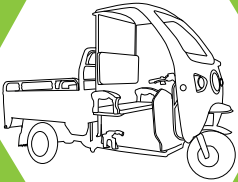

Please, read this manual thoroughly before using your tricycle.

## PREFACE

This product is designed environment-friendly. You will see advantages and characteristics of the product in this manual. This manual has safety, maintenance and storage instructions. The high-technology tricycle you have purchased has the following parts:

- Efficient brushless DC motor
- Digital drive head with display protecting from high and low voltage
- Coast brake for safe drive
- High-capacity batteries for longer range and high performance
- Front and rear suspensions for a pleasing and comfortable drive
- Motorcycle equipment complying with European standards

This manual of your tricycle will be an indispensable part of it. Make sure that you get it with your tricycle.

If, there is any problem with your tricycle, never use any part other than originals provided by an authorized service.

This manual is prepared for electric tricycles of Volta Motor. Images and technical specifications in the manual might not be identical with your tricycle. Main purpose of this manual is to promote the product and ensure safe operation.

Thank you for choosing our product. Wish you pleasing and safe drives with your electric tricycle.



**WARNING** - These headings are written for preventing fatal accidents and personal injuries.



**ATTENTION** - These headings are written for preventing you from severe personal injuries and mechanical damages



## CAUTION

- Laws restrict driving electric tricycles with age and driver's license. Drivers with a driver's license in any class can safely use the electric tricycle. Please, pay attention that the persons to drive it have a driver's license. (In some European countries, they can be driven with special certificates.)
- Do not change, remove or modify any part without notifying the authorized service. Changes without authorization of the authorized service distorts originality of your product and nullify product guarantee. Please, do all changes at authorized service locations.
- Modification is not legal. Main structure, performance of modified vehicles is influenced. This will also shorten the life of your tricycle. Furthermore, modified tricycles will be out of guarantee. Always use spare parts authorized by the distributor.
- This manual is supplied with the product.

# TABLE OF CONTENTS

Preface .....	02
1. Devices and Accessories .....	05
2. Displays .....	09
3. Charging the Battery .....	13
4. Driving Instructions .....	15
5. Instructions for a Safe Drive .....	18
6. Maintenance and Care .....	21
7. Storage Guide .....	26
8. Troubleshooting .....	27
9. Technical Specifications .....	28
10. Authorized Service .....	29
11. Guarantee .....	30

# 1. DEVICES AND ACCESSORIES

VM4



1- Headlight

2- Mirror

3- Brake Handle

4- Display Panel

5- Starter

6- Seat

7- Rear Stop Light and Signals

8- Signals

9- Front Wheel

10- Wind Spoiler

11- Motor

12- Rear Wheels

13- Compensating Wheel

# 1. DEVICES AND ACCESSORIES

VM4+



1- Headlight

2- Mirror

3- Display Panel

4- Brake Handle

5- Starter

6- Front seat

7- Backseat

8- Signals

9- Front Wheel

10- Wind Spoiler

11- Motor

12- Rear Wheels

13- Rear Stop Light and Signals

14- Rear Bucket

# 1. DEVICES AND ACCESSORIES

VMS



1- Headlight

2- Front Signals

3- Front Bucket

4- Disk Brake

5- Front Wheel

6- Display Panel

7- Right-Left mirror

8- Throttle Lever

9- Backrest

10- Front Seat

11- Backseat

12- Backrest of the Backseat

13- Rear Bucket

14- Rear Stop Light and Signals

# 1. DEVICES AND ACCESSORIES

VTS

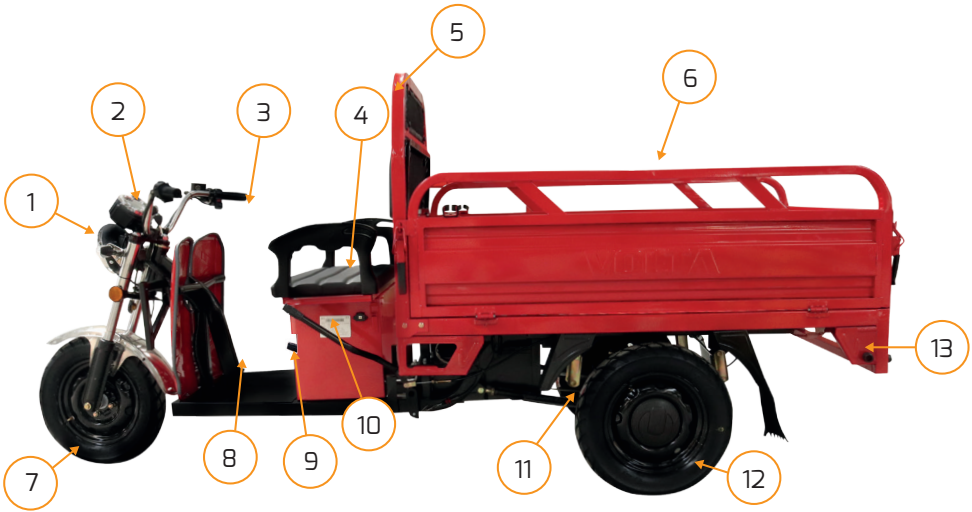

1- Headlight

2- Display Panel

3- Throttle Lever

4- Seat

5- Backrest

6- Safety Deposit Box

7- Front Wheel

8- Footbrake

9- Hand Brake

10- Stiffener

11- Motor

12- Rear Wheels

13- Stop Light and Signals

**⚠ WARNING** - Please, do not pull the stiffener while driving the tricycle.



## 2. DISPLAYS

VM4 - VM4+



1- Main and dipped beam setting button

2- Mirror

3- Display Panel

4- If, you turn the throttle lever counter-clockwise while the starter is on, the vehicle gains speed. Your speed is related with the angle of throttle lever.

5- Signal button "◀" indicates left turn, "▶" indicates right turn.

6- Horn

7- Forward backward button

8- Light on-off button

9- Electronic transmission

### DISPLAY INDICATORS



Motor  
Fault



Throttle  
Lever Fault



Brake Fault



Driver Fault



GEAR



Headlight



Remaining  
Power

**! WARNING** - All parts listed in the manual are for reference purposes. Manufacturer firm can change them without any notification.

**! ATTENTION** - Do not use your horn in forbidden zones.

## 2. DISPLAYS

VMS



1- Main and dipped beam setting button

2- Right-left signal: Signal button "◀" indicates left turn "▶" indicates right turn

3- Horn

4- On-off button.

5- Forward backward button

6- Headlight on-off button.

7- If, you turn the throttle lever counterclockwise while the starter is on, the vehicle gains speed. Your speed is related with the angle of throttle lever.

8- Electronic transmission

### DISPLAY INDICATORS



Headlight



Remaining Power



Brake Fault



GEAR Gear



**WARNING** :- All parts listed in the manual are for reference purposes. Manufacturer firm can change them without any notification.



**ATTENTION** - Do not use your horn in forbidden zones.

## 2. DISPLAYS

VTS

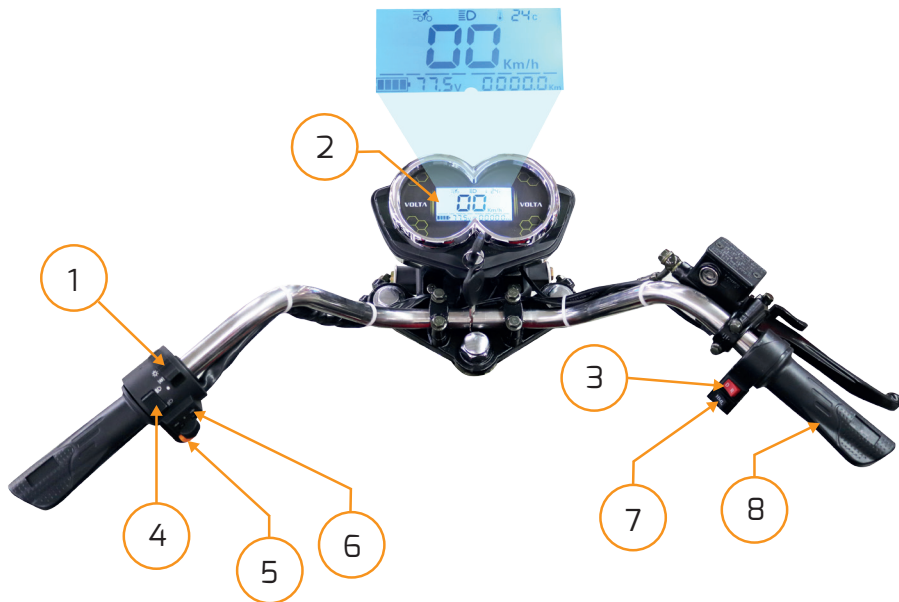

1- Headlight on-off button

2- Display Panel

3- Forward backward button

4- Main and dipped beam setting button

5- Horn

6- Signal button "◀" indicates left turn, "▶" indicates right turn,

7- Electronic transmission

8- If, you turn the throttle lever counterclockwise while the starter is on, the vehicle gains speed. Your speed is related with the angle of throttle lever.

### DISPLAY INDICATORS



Remaining  
Power



Ambient  
Temperature



Headlight



**WARNING** - All parts listed in the manual are for reference purposes. Manufacturer firm can change them without any notification.





**ATTENTION** - Do not use your horn in forbidden zones.



## 2. DISPLAYS

### 2.1 Starter





"Different models can have different starter symbol and design"

**2.1.1 Turning On/Off** : Place the ignition key and turn it from  to  Tri-cycle will start. Otherwise, it will stop.

**2.1.2 Steering Lock** : Your tricycle has steering lock function to prevent it getting stolen. Your steering wheel will be locked if you turn it to leftmost  Likewise, if you turn it slowly right while turning to  symbol, it will be unlocked.

**2.1.3 Seat Lock** : If, you insert the key in the keyhole beside your seat and turn it left while slowly lifting your seat up, it will be unfolded. If, you fold it, it will be locked, automatically.

 **WARNING** - Do not drag your tricycle while your steering is locked. Your tricycle might rollover as the steering is in a single direction.

 **ATTENTION** - Lock your steering where you park and remove the key. By this way, your tricycle will be safe.

Protect your tricycle from direct sunlight. ABS plastic parts and paint of your tricycle exposed to direct sunlight react to high temperatures and UV beams. Your tricycle turns color. Protect your tricycle from direct sunlight. Do not expose it to sunlight when you do not use it.

### 3. CHARGING THE BATTERY

Charge your electric tricycle 6-8 hours with the supplied charger before first drive. You must charge batteries after every drive. If, you will not use it for a month or longer, you must charge it for preserving battery performance. Charge time is 6-8 hours for lead-acid batteries. (This time is for fully depleted battery, charge batteries in proportion with its depletion. Electrical installation is set to 230V AC supply. Higher or lower voltage can damage your charger and your charges might not stop charging after filling the batteries. This may cause swelling for batteries, if they are charged more than maximum charging time due any reason. Please, issue a failure log for your long-term charging chargers. In winter months, battery capacity will decrease a little. Try to maintain them full as much as possible.

#### 3.1. Charging Battery on Tricycle

Turn off the electric tricycle. Plug the part of charger indicated with 1 to your tricycle and with to a socket. → Firstly, plug in your charger and then connect it to the tricycle. Thus, possible high/low voltage will harm your charger rather than your tricycle. If, indicator on the battery is green, the battery is completely full. After, it is full, if you remove it from charger and replug it again for 1-2 hours, you will have a better charge. When, charge is completely over, remove the charger. In addition, remove the plug from mains socket when you do not use the charger. This will extend the life of your product.

### 3. CHARGING THE BATTERY

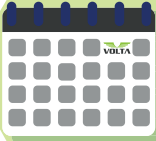

- If, you charge the battery at least once in a month, it will extend its life.

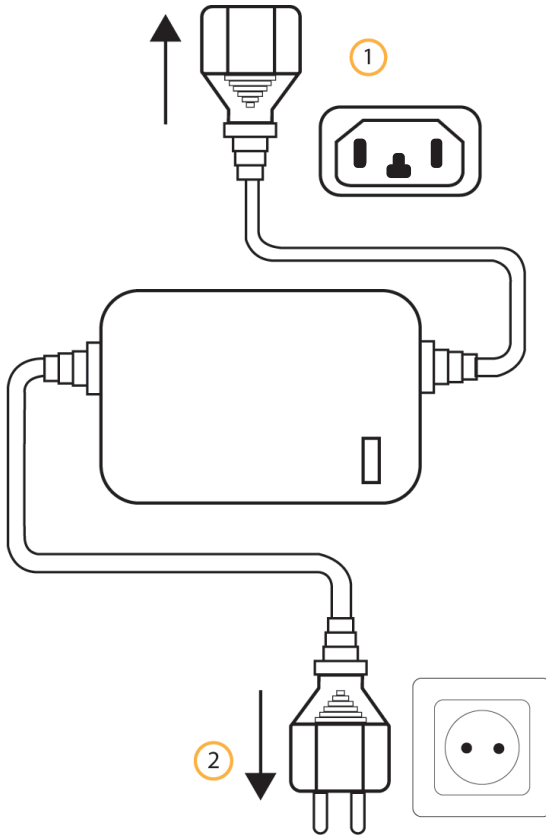

**ATTENTION** - A charger damaged by voltage differences in your electrical installation might harm your tricycle. Such problems are not considered within the guarantee. Therefore, please remove the charger from tricycle if it is not charged.

## 4. DRIVING INSTRUCTIONS

### Connection and Assembly

Connection and assembly are only done by authorized services.

#### 4.1 Check the Parts Below Before a Drive

**4.1.1** Check your tires are good.

**4.1.2** Check the condition of moving parts.

**4.1.3** Check tire pressures.

**4.1.4** Check horn and rear-view mirrors.

**4.1.5** Make sure all bolts and nuts are tightened sufficiently. Also, check brake cable and other cables are not entrapped and working properly.

**4.1.6** Charge your batter while it is not used. In idle terms, charge it in every 30 days during summer and 15 days during winter.

**4.1.7** Check all rotating parts, if oil levels are low, add.

**4.1.8** Check all lighting systems

#### 4.2 Driving Instructions

**4.2.1** Hold the handlebar tightly and balance completely.

**4.2.2** Turn the starter ON.

**4.2.3** Put your right hand on throttle lever. Turn it slowly for avoiding surge. Tricycle will gain speed as you turn the throttle lever. Remove your hand from the throttle lever for stopping you tricycle and pull brake lever slowly to you. If, you pull brake lever, throttle will be automatically stopped.

## 4. DRIVING INSTRUCTIONS

### 4.3 Seat

**4.3.1 Seat Lock:** There is a keyhole under left side of your seat. If, you insert your key and turn it counterclockwise, your seat will be unlocked.

**4.3.2** Lower it slowly and close. It will be locked automatically.

### 4.4 Front and Rear Brakes

Left and right brake levers are loose 10-20 mm before functioning. This is called free space. This can be set by tightening or loosening nuts.

 **WARNING** - Tire pressure is very important for total life of your tricycle and proper operation of the system.

Excessively low/high tire pressure will harm your tricycle. Tire pressure recommended by us for tricycles is 30 PSI.

 **ATTENTION** - Brakes can be set based on sensitivity. Front and rear brakes should be used jointly for safer slowing.

Do not use brakes for long. If, you pull the brake for long, brake sets overheat and lose their performance. This extends your braking distance.

Please, release the throttle lever while pulling brake levers



## 4. DRIVING INSTRUCTIONS

### 4.5 Park Brake

While, your tricycle is in "P" mode, park brake is active. While, park brake is active, your tricycle does not move when you gas. This is a precaution for your starting safety.



### 4.6 Differential

Differential enables tires rotate in different speeds based on the corner you turn. Inner tires of your tricycle rotate slower while outer ones faster when, you turn a corner. The path taken by the outer tire while taking a corner is longer than the inner tire.

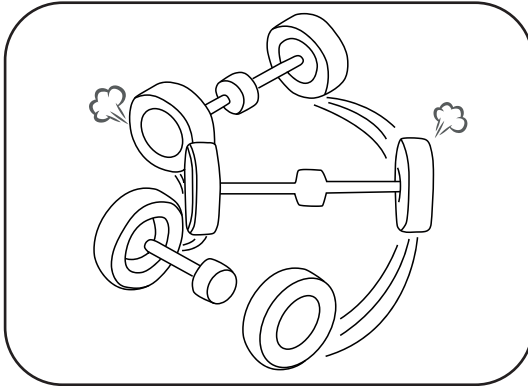

**NOTE :** Oil in differential should be checked and replaced in 180-day maintenance period. Permanent damage might arise if it is not replaced.

## 5. INSTRUCTIONS FOR A SAFE DRIVE

### 1.1 General Rules

**1.1.1** Always wear your helmet while driving your tricycle. Also, pay attention that your helmet is used in accordance with related directives and it perfectly fits your head.

**1.1.2** Follow all rules of traffic, all other land vehicles follow, as stopping at red light, yielding pedestrians, beaming at turns, etc. while driving.

**1.1.3** Drive your tricycle on a straight line. Adopt a defensive driving attitude considering it will be difficult for other land vehicles to see you.

**1.1.4** Concentrate on the road in front of you. Avoid pits, water and oil puddles, ramps, gravel and all other obstacles on the road.

**1.1.5** Drive considering unexpected thing as instant opening vehicle doors, parts falling from vehicles, etc. Be very careful at intersections and overtaking.

**1.1.6** Do not hit the roads before getting accustomed to using functions as signals, brakes, horn, etc.

**1.1.7** Do not take passengers and packages to make it difficult for you to drive your tricycle and prevent your sight. Also, avoid earphones which will block your hearing while driving.

**1.1.8** Keep your safe driving distance with vehicles, pedestrians and all other objects. Safe driving distance changes by weather conditions.

**1.1.9** Drive slowly under unfavorable road conditions.

**1.1.10** Please, do not exceed maximum bearing capacity. If, you exceed it, indicated range will be shorter. If you exceed maximum bearing capacity, this might cause permanent damages on the tricycle.

### 1.2 Rainy Weather

**1.2.1** Show more attention on wet surfaces.

**1.2.2** Brake earlier considering that your stopping distance will extend on wet surfaces.

## 5. INSTRUCTIONS FOR A SAFE DRIVE

**1.2.3** Slow down, avoid braking suddenly and pay more attention at corners.

**1.2.4** Wear clothes to make you more visible on the road.

**1.2.5** Wear reflectors and use safety lights.

**1.2.6** Holes, ramps, dyed parts and railroad crossings become more dangerous under rain, please be careful.

### 1.3 Night Drive

**1.3.1** Make sure your lights are on

**1.3.2** Use your tricycle at nights only if you have to. If possible, use lighted roads you know.

### 1.4 Brake system

**1.4.1** Brake system of your tricycle is equipped with drum brake and lining system. If, the brake system is used by hands, central brake, if by foot, rear wheel braking is applied.

This brake system is vital for your safety. Have your control and setting processes in periods given in the periodical maintenance schedule done by authorized services.

Please, check the brake system before every use based on the following instructions:

- Make sure there is not any trip in the brake system,
- Make sure there is not any ruptured brake wire or removed connection,
- Check whether brake linings are worn,
- Check whether the brake lever and brake pedal are flexible enough.
- Brake distance affects your stopping range under rain.

### 1.5 Tires

**1.5.1** For your safety, care your tires and check tire pressure in addition to periodical maintenances

## 5. INSTRUCTIONS FOR A SAFE DRIVE



- Brake distance affects your stopping range under rain.

**WARNING:**

**1.5.2** The tires on your tricycle are original parts of it, provided that the size is the same, choose the best tire by considering conditions of the season and use.

**1.5.3** Abrasion and handling of your tires are based on conditions of use. Particularly based on driving style, load, speed, field, surface structure and particularly road contact.

**1.5.4** Tire problems based on tire pressure mainly derive due to faulty inflation pressures. Tire pressures should be set while tires are completely cold. Even 2-3 km drive will warm up air in tires, therefore this can be misleading. Tire pressures must be at the indicated limits and tire pressure values are given as the maximum values for front and rear tires. Deficient pressure accelerates tire wear, weakens turning ability, tire warms up fast, as more load will be born by sidewalls, this causes cracks and slits and this will also increase fuel consumption. Overpressure causes driving roughly and feeling road impacts more, decreases contact with road and loss of control and skids. Furthermore, overpressure does not increase load bearing capacity.

## 6. MAINTENANCE AND STORAGE

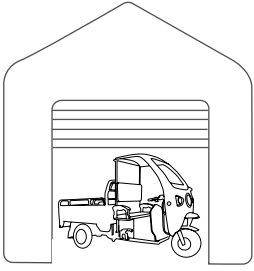

**WARNING**

- Store your tricycle away from cold, if possible, in your garage. By this way, the battery life will be longer.

### 6.1 Battery

**6.1.1** Do not remove the batteries.

**6.1.2** Keep away from children.

**6.1.3** Do not join anode and cathode of the charges while charging or discharging. Do not use any conductor between the anode and the cathode. This will cause short-circuit.

**6.1.4** Avoid any water contact with the battery.

**6.1.5** Protect batteries from 60oC and higher temperatures.

**6.1.6** Do not expose them any physical impact as hitting, throwing, dropping, etc.

**6.1.7** Do not tamper with perforating, cutting tools.

**6.1.8** If, there is any leakage and this contact with your skin or eye, immediately rinse with plenty of water and consult the closest healthcare institution.

**6.1.9** If, you detect any physical change as odor, warming, color change, etc. on the battery, immediately remove it from your tricycle and move away.

### 6.2 Charger

**6.2.1** Only use the original charger designed for your tricycle.

**6.2.2** Your tricycle must be OFF while being charged.

**6.2.3** Do not tilt the tricycle while charging.

## 6. MAINTENANCE AND STORAGE

### 6.3 Cleaning

**6.3.1** It is recommended to clean your tricycle with a wet cloth.

**6.3.2** Do not lubricate the brake system and tires in anyway.

**6.3.3** Use lubricant for cleaning metal parts of your tricycle.

**6.3.4** Always use standard cleaning materials while cleaning dyed plastic parts. Dry with fabric after cleaning.



**WARNING:**

- Do not use pressurized water for washing your tricycle; this might cause penetration of water in some parts of your tricycle. The leaking parts may lose performance and break down.



## 6. MAINTENANCE AND STORAGE

### 6.4 Brake Test

#### 6.4.1 Drum Brake:

**6.4.1.1** Press the joint section (1), tighten the setscrew (3), simultaneously hold the brake lever (2) and tighten the brake (B-C)  $\frac{1}{3}$ - $\frac{1}{2}$  of the designed A-C distance

**6.4.1.2** Place the brake in the drum and tighten at the best rate you consider for tightness and performance.

**6.4.1.3** Optimum braking is achieved when the distance between brake lining and inner surface of drum is 1.5mm.

**6.4.1.4** Replace the lining when it is half of the unused form.

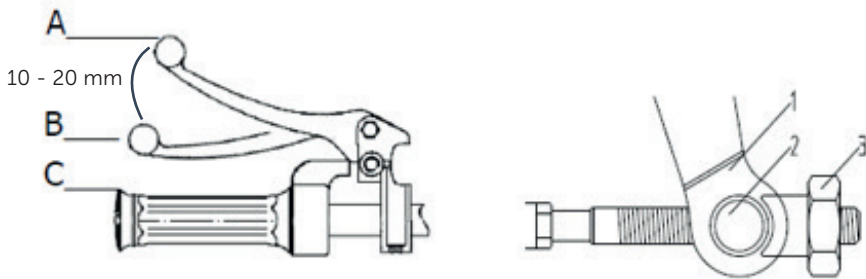

#### 6.4.2 Disc Brake

**6.4.2.1** . The brake lever at the right side of the handlebar is for disk brake. There is about 10-20 mm empty space between A-B positions.

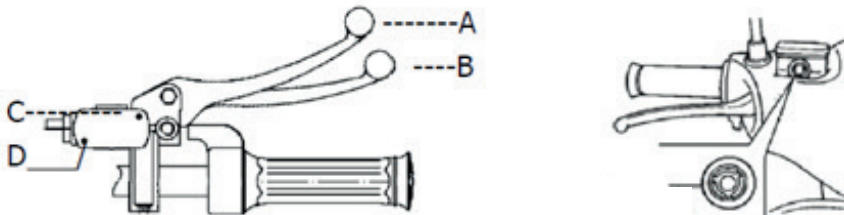

**6.4.2.2** . If, empty space is not 10-20 mm, this means the brake fluid is low. Remove the C and D bolts and add brake fluid to the opened section.

## 6. MAINTENANCE AND STORAGE

### 6.5 Maintenance of the Motor and Driving Head

**6.5.1** Do not let water level reach the central shaft of the motor under rain. This will protect the motor from breaking down.

**6.5.2** In order to protect other parts, do not give gas and apply brakes simultaneously.

**6.5.3** Slow down while the road surface is rough. Excessive vibration can cause cables in the motor and the drive rupture.

### 6.6 Periodical Maintenance

 **ATTENTION** - 180-day periodical maintenance must only be done by authorized services. Daily and 60-day maintenances can be done by the consumer.

● Control   ◆ Adjust   ▲ Change   ■ Lubricate

	Daily	60 Days	180 Days
Tire pressure	●		
Horn	●		
Bulbs	●		
Charge device and batteries	●		
Brake	●	● ◆	● ◆
Rim		●	●
Front fork		●	●
Gas lever and rotating parts		● ■	● ■
Brake system			◆



- Tricycles which are not periodically maintained (once in every 4 months) will be out of guarantee.



## 6. MAINTENANCE AND STORAGE

First maintenance of your tricycle should be done at 500 km or the end of the 1st month. First maintenance is for control purposes. Your first maintenance after this will be done when it reaches 2000 km. After, this maintenance, all your maintenances will be in every 2000 km.

The maintenances for the first 20000 km are as follows.

- 500 km maintenance
- 2000 km maintenance
- 4000 km maintenance
- 4000 km maintenance
- 8000 km maintenance
- 10000 km maintenance
- 12000 km maintenance
- 14000 km maintenance
- 16000 km maintenance
- 18000 km maintenance
- 20000 km maintenance

Term between two maintenances must not exceed 4 months. The consumers, who cannot reach the aforementioned maintenance ranges in more than 4 months, should take their tricycles to authorized service for maintenance. The tricycles which do not follow maintenance periods and km will be out of guarantee.

### 6.7 Handling

While handling your tricycle, make sure that the starter and the fuse are OFF. Also, remove one of the battery connections. Tighten the front and rear brakes. In order to prevent any external damage on your tricycle, you can carry it safely by coating cardboard on a metal cage.

## 7. STORAGE GUIDE

### Storing

- If, you will not use your tricycle for a long time, in winter, etc., you should take some precautions for protecting it from problems and abrasion. It is better to do some repairs before storing.
- Wash, rinse and dry your tricycle. If, you apply protective oil on dyed surfaces, life of your paint will extend and maintain its brightness.
- Set the tire pressure of your tricycle at the ideal tire pressure level.
- Cover it with a non-plastic or non-rubber top. Care to store under conditions where temperature does not vary much. High temperature changes might cause fatigue, breaking or cracking on several parts of your tricycle.

### Re-commissioning the Tricycle

- Remove the top on your electric tricycle and clean it.
- After, fulfilling all pre-startup instructions, start your electric tricycle.
- Drive it for the first time in an area closed to traffic. Hit the roads after making sure that all parts of your electric tricycle work properly and at full performance.

### Loading

- Do not carry inappropriate loads on your electric tricycle. Otherwise, related parts will be damaged

## 8. TROUBLESHOOTING

PROBLEM	REASON	SOLUTION
Power light is on but your electric tricycle does not move.	<ol style="list-style-type: none"><li>1. Throttle lever does not function.</li><li>2. Park brake might be fixed.</li><li>3. Brake arresters might be faulty.</li></ol>	<ol style="list-style-type: none"><li>1. Replace the throttle lever.</li><li>2. Turn off the park brake.</li><li>3. Consult the authorized service.</li></ol>
Your electric tricycle does not start even the starter is ON.	<ol style="list-style-type: none"><li>1. Fuse or fuse socket is burnt.</li><li>2. Battery connections are not right.</li></ol>	<ol style="list-style-type: none"><li>1. Replace the fuse or fuse socket.</li><li>2. Do the battery connections properly.</li></ol>
Range is less	<ol style="list-style-type: none"><li>1. Tire pressure is low.</li><li>2. Battery is not full.</li><li>3. Frequent stops and goes, overloading, climbing up hills and exposing winds</li></ol>	<ol style="list-style-type: none"><li>1. Inflate your tires.</li><li>2. Charge or replace your batteries.</li><li>3. Drive under indicated road conditions.</li></ol>
Electric tricycle is not charged.	<ol style="list-style-type: none"><li>1. Main fuse may be off.</li><li>2. Charger may be faulty.</li><li>3. Charge socket may be out.</li></ol>	<ol style="list-style-type: none"><li>1. Switch on the fuse.</li><li>2. Consult the authorized service.</li><li>3. Consult the authorized service.</li></ol>
Electrical tricycle decelerates	<ol style="list-style-type: none"><li>1. Low battery.</li><li>2. Faulty battery</li></ol>	<ol style="list-style-type: none"><li>1. Charge your batteries fully.</li><li>2. Replace your batteries</li></ol>

### NOTE

If, any fault arises, please do not try to repair it on yourself. Please, contact the closest authorized service.

## 9. TECHNICAL SPECIFICATIONS

Parameters	Properties	VM4	VM4+	VM5	VT5
Dimensions	(Length x Width x Height) [cm]	1570/710/1080 mm	1960/740/1080 mm	2270/970/1110 mm	3070/1280/1412 mm
Weight	Birim (kg)	112 kg	130 kg	219 kg	345 kg
Main Properties	Maximum Speed (km/h)	25 km/h	25 km/h	35 km/h	42 km/h
	Range (km)	40 km	35 km	35 km	50 km
Battery Characteristics	Voltage (V)	60 V	60 V	60 V	72V
	Capacity (Ah)	22 Ah	22 Ah	22 Ah	60Ah
	Battery	VRLA Jel	VRLA Jel	VRLA Jel	VRLA Jel
	Charger Properties	60V/20A	60V/20A	60V/20A	72V/40A 72V/60A
Motor Properties	Voltage(V) Power (W)	60V 1500 W	60V 1500 W	60V 1500 W	72V 3900 W
Display	Display Type	LCD bilgi ekranı	LCD bilgi ekranı	LCD bilgi ekranı	LCD bilgi ekranı

## 10. AUTHORIZED SERVICE

You can see locations of our authorized services by visiting [www.volta.com.tr](http://www.volta.com.tr)



### MANUFACTURER

#### **Volta Motor Sanayi A.Ş.**

Merkez Mh. Yıldıztepe Cad. NO:10

Gümüşova OSB Gümüşova / DÜZCE

Tel : 0850 222 28 65 - 0380 731 25 25



## MANUFACTURING COMPANY

Title	Volta Motor Sanayi ve Tic. A.Ş.	
Address	Merkez Mh. Yıldıztepe Cad. No:10 Gümüşova OSB Gümüşova/DÜZCE	Tübitak MAM Teknoloji Serbest Bölgesi Barış SB. Mh. 5001 Sk. No:3 A/B GEBZE/KOCAELİ
Phone	+90 380 731 25 25	+90 850 222 28 65
Fax	+90 380 731 25 35	+90 380 731 25 35

## OF THE PRODUCT

TYPE	TRICYCLES
BRAND	Volta
MODEL	
CHASIS NUMBER	
DELIVERY DATE and PLACE	
MAXIMUM REPAIR DURATION	45 BUSINESS DAYS
WARRANTY PERIOD	2 YEARS

## SELLING COMPANY

TITLE	
ADRESS	
PHONE	
FAX	
INVOICE DATE AND NUMBER	
DATE OF SALE	

This part has to be completely filled by the seller. (STAMP-SIGNATURE)

## CONDITIONS AND SCOPE OF GUARANTEE

1. Guarantee term is two years and this Guarantee Certificate must be kept as it is necessary to submit it for benefiting from guarantee.
2. Including all parts of the product, the entire product is within the guarantee scope.
3. If, it is determined that the product is defective, the consumer is entitled to the rights in the 11th Article of the 6502 numbered Consumer Protection Law;
  - a) Rescission of the contract by indicating that he/is ready to return the sold product,
  - b) Accepting the sold product and demanding discount from the sales price proportional to the concerned defect,
  - c) Demanding the product is repaired by the seller provided that repair costs are not high,
  - d) If possible, demanding replacement of the sold product with another one without any defect.
4. As the invoice will be taken as basis for any conflict during guarantee term, it is necessary to submit the approved Guarantee Certificate and the invoice.
5. If, any falsification is done on the invoice and/or the guarantee certificate, original serial no. on the tricycle is removed or damaged, guarantee is null and void.
6. If, maintenance or repairs of the tricycle is done by third parties other than our authorized services or if this is determine, guarantee is null and void.
7. The tricycles must be maintained by authorized services in the periods indicated on the manual. The tricycles which are not maintained in time will be out of guarantee.
8. The guarantee of our firm does not cover the following problems as well as any problem caused by using the tricycle for purposes other than intended ones or under abnormal conditions-;
  - Problems arising adding any parts on the tricycle, which are not manufactured/sold by Volta Motor,
  - Penetration of water in parts after the tricycle passes in deep water higher than the rear wheel shaft or it is washed by pressurized washing machines,
  - Abrasion, wear and tear of axle, differential, transmission, motor, rim, etc. parts of the tricycle by using it under loads higher than maximum bearing capacities indicated on technical documentation,
  - Problems arising due to modifications done without consent of Volta Motor,
  - Abrasion, wear and performance loss of parts as battery, brake lining, rubber parts, belts, etc.
  - Charging the tricycle with a charger other than the original one or charger fails due to electrical installation or voltage changes and harms the tricycle (batteries),
  - Expansion (swelling) or failure of batteries due to overcharging of the tricycle longer than the time indicated by the firm,
  - Fluid contact to charger and other electronic parts,
  - Loading suspension and chassis connection parts higher than the bearing capacities written in the manual or breaking, bending due to impacts-,
  - Damages and failures due to natural disasters as fires, floods, storm water, lightning strikes, etc.,
  - Batteries are products with shelf-life. Batteries kept uncharged for more than 90 days (by the dealer or the end consumer),
  - Damages arising after delivery of the tricycle to the user, during loading, unloading and handling of it.
9. No one, other than the consumer with the identity information on the Invoice and Guarantee Certificate of the Tricycle, can make any claim or compensation.
10. The consumer can appeal to the Consumer Arbitration Committee or the Consumer Court where he/she is registered or the consumer process is done for conflicts which might arise related with exercising of guarantee related rights.



[www.volta.com.tr](http://www.volta.com.tr)

## DÜZCE

Merkez Mh. Yıldıztepe Cad. No:10  
Gümüşova OSB Gümüşova / DÜZCE

☎ 0380 731 25 25

✉ [info@volta.com.tr](mailto:info@volta.com.tr)

## GEBZE

Tübitak MAM Teknoloji Serbest Bölgesi  
Barış SB. Mh. 5001 Sk. No:3 A/B  
GEBZE / KOCAELİ

☎ +90 850 222 28 65

✉ [info@volta.com.tr](mailto:info@volta.com.tr)